



Product Description

Designed to provide general area air flow

Outer nozzle rotates 360 degrees to direct air

Plastic side shutter for air flow volume control

Aluminum housing and outer nozzle

Standard finishes are clear or black anodize

Available in custom plated finishes

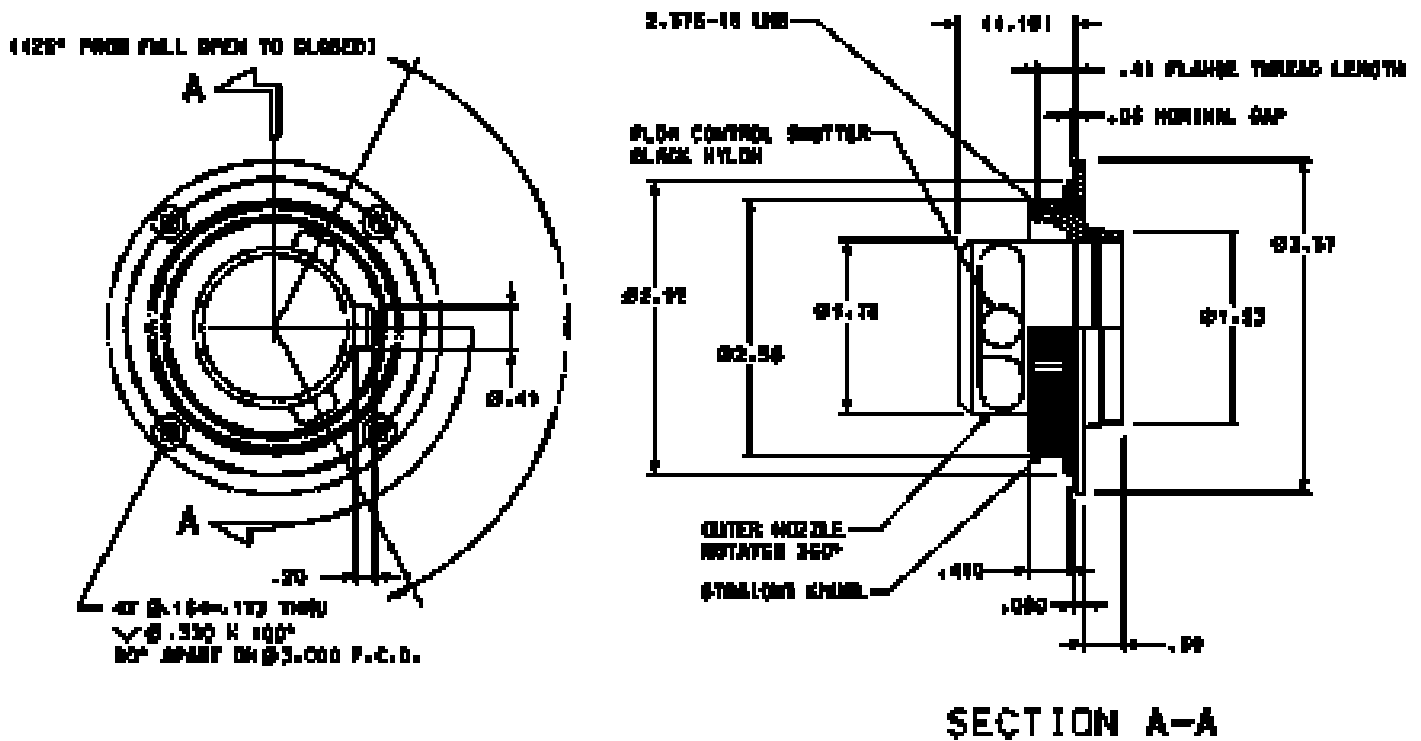

This shutter type air valve is designed to provide a stream of air along ceiling panels and headliners. Pushing a knob on the black plastic shutter opens the orifice which controls the volume of air flow through the air valve. The shutter is contained in a housing which rotates 360 degrees to direct the flow of air. Common applications are cockpit and galley areas where an additional air valve is necessary to supplement other air distribution equipment. The air valve is installed with four screws and has a cosmetic closeout ring for securing the adjacent panel.

14321 Commerce Drive
 Garden Grove CA, 92843

Phone: 714-554-9782
 Fax: 714-554-3659
 www.birkaero.net