



## Product Description

Durable plastic switch module

Two buttons, reading light, and table light

Black retainer enables easy installation

Standard black color, custom colors available

Wire harness termination

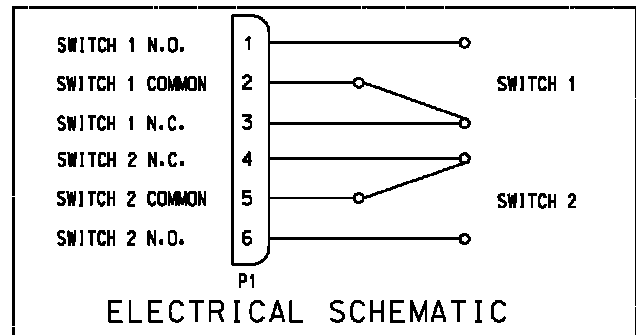
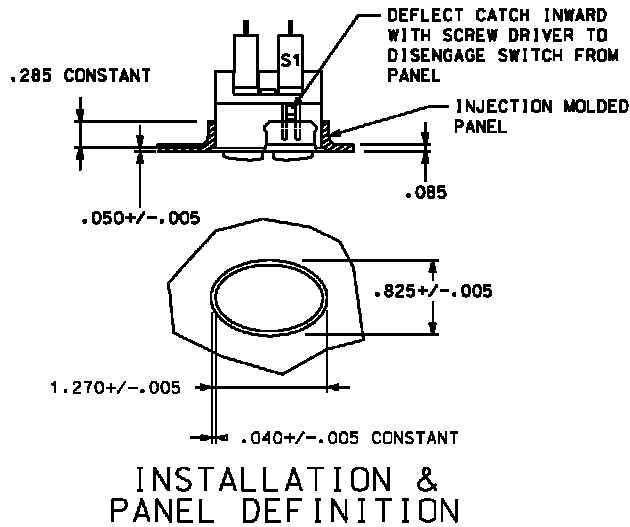
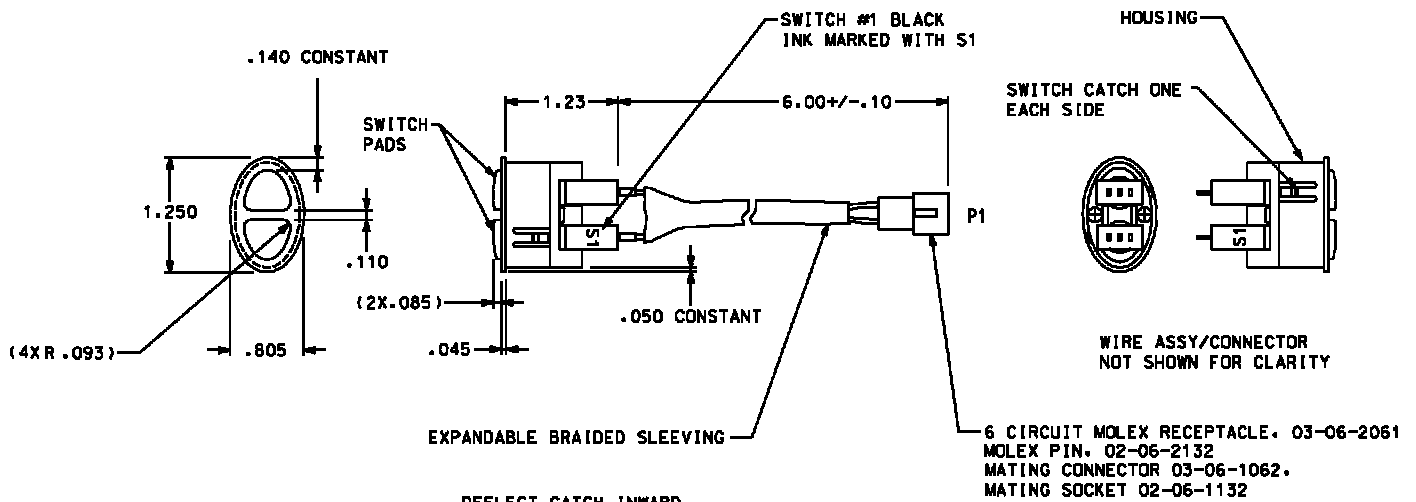

This small switch assembly is designed to switch power to a reading light and adjacent table light. Typical applications are overhead reading light and air valve panels. The switch assembly is secured by installing retainer part number 12521-1 which is available as an accessory.

14321 Commerce Drive  
Garden Grove CA, 92843

Phone: 714-554-9782  
Fax: 714-554-3659  
www.birkaero.net