



Product Description

Exterior finger grip nozzle design

Durable aluminum construction

Recessed ball minimizes cabin protrusion

1.50 inside diameter nozzle

Mounting nut type installation

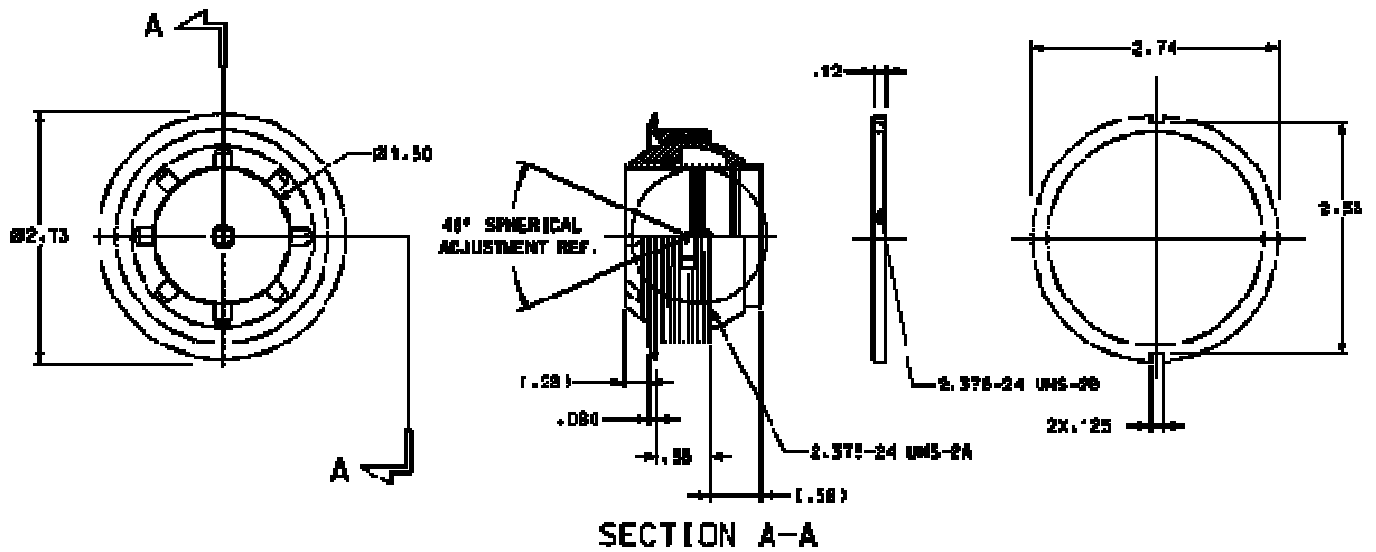

This disc type air valve is designed for high flow volumes at low duct pressure. The air valve has minimal cabin protrusion and is designed for main cabin passenger cooling applications. Other applications are crew areas and galleys.

14321 Commerce Drive
Garden Grove CA, 92843

Phone: 714-554-9782
Fax: 714-554-3659
www.birkaero.net